

# QS1A

- Single unit connects up to four solar modules
- 4 input channels with independent MPPT and monitoring function
- Maximum continuous output power up to 1500W
- UL 1741 compliant
- Accommodates 60 & 72-cell PV modules up to 525W+

## DIMENSIONS

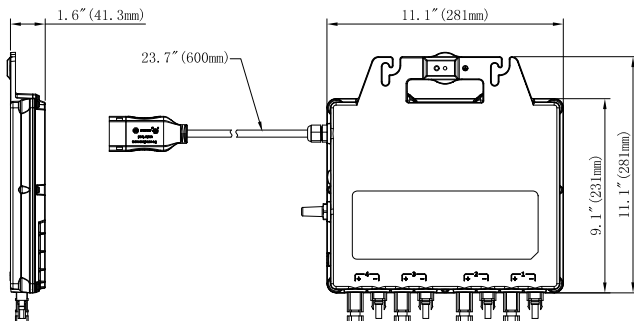

The APsystems QS1A is a grid-tied microinverter with UL 1741 compliant. High efficiency, high reliability of the QS1A with 4 independent MPPT inputs, maximum continuous AC output power reaching 1500W. Quarter the inverters and quarter the installation means real cost savings for residential and commercial customers.

## WIRING SCHEMATIC

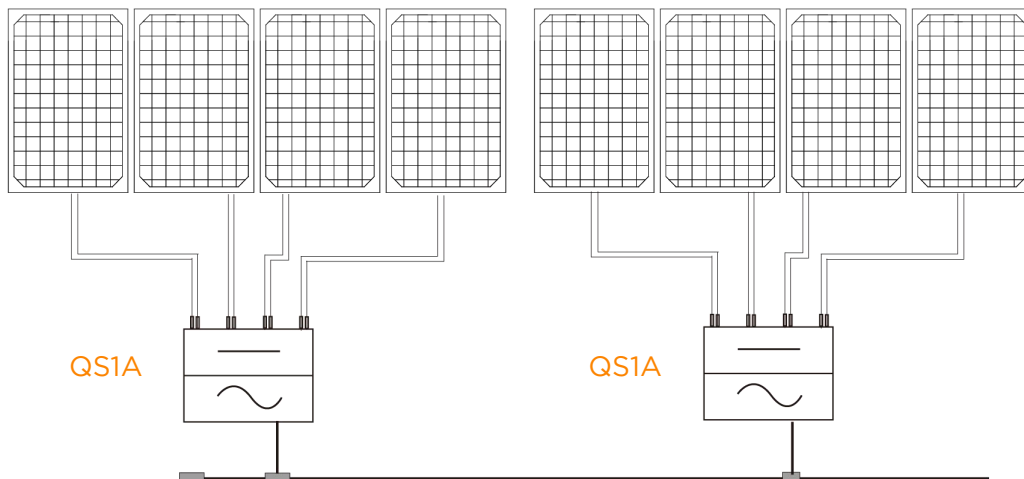

# QS1A Microinverter Datasheet

## Region

## LATAM

### Input Data (DC)

Recommended PV Module Power (STC) Range	250Wp-525Wp+
MPPT Voltage Range	30V-52V
Operation Voltage Range	16V-55V
Maximum Input Voltage	60V
Startup Voltage	20V
Maximum Input Current	13.3A x 4
Maximum DC Short Circuit Current	15A x 4

### Output Data (AC)

Maximum Continuous Output Power	1500W
Nominal Output Voltage/ Range	240V/ 211V-264V
Adjustable Output Voltage Range	150V-280V
Nominal Output Current	6.25A
Maximum Units per Branch	2units per 20A AC breaker/ 3units per 25A AC breaker
Nominal Output Frequency/ Range	60Hz/ 59.3Hz-60.5Hz
Adjustable Output Frequency Range	55Hz-65Hz
Output Power Factor Rating	>0.99
Total Harmonic Distortion	<3%
Maximum Output Fault Current (AC) and Duration	47.3 Apk, 1.4 ms of duration

### Efficiency

Peak Efficiency	96.5%
Nominal MPPT Efficiency	99.5%
Night Power Consumption	30mW

### Mechanical Data

Operating Ambient Temperature Range	-40°F to +149°F (-40°C to +65°C)
Storage Temperature Range	-40°F to +185°F (-40°C to +85°C)
Dimensions (W x H x D)	11.1" x 9.1" x 1.6" (281mm x 231mm x 41.3mm)
Weight	9.9lbs (4.5kg)
AC BUS Maximum Current	25A (12AWG)
Enclosure Rating	Type6
Cooling	Natural Convection - No Fans

### Features

Communication	Wireless
Transformer Design	High Frequency Transformers, Galvanically Isolated
Monitoring	Via EMA* Online Portal

### Certificate & Compliance

Compliance	UL1741 (IEEE1547); CSA C22.2 No. 107.1; NOM-001
------------	---

\*APsystems online Energy Management Analysis (EMA) platform.



Specifications subject to change without notice - please ensure you are using the most recent update found at [latam.APsystems.com](http://latam.APsystems.com)

© All Rights Reserved

APsystems en Guadalajara:

AV. Lazaro Cardenas 2850-5o Piso, Colonia Jardines del Bosque C.P. 44520, Guadalajara, Jalisco

+52 1 33 3188 4604 | 01 800 890 6030 | [info.latam@apsystems.com](mailto:info.latam@apsystems.com)